

Hydrostatic Cylinder Testing

"BECOMING A PROFESSIONAL HYDROSTATIC TESTER"

MAKING THE RIGHT EQUIPMENT DECISIONS.

Making the right equipment decisions up-front often determines just how successful you will be. Since 1962 Galiso has manufactured and installed thousands of the finest, most reliable hydrostatic systems and support equipment for everything from the largest major cylinder manufacturing facilities, to the smallest start-up operations. Our interest in your business is in helping you select the right tools to **maximize profitability**.

EXPERIENCE COUNTS.

Over the years we've listened, watched, and responded with answers to many commonly asked questions. From this, we have helped thousands of retesters succeed in their business. We have also watched people stumble down the wrong path, and we would like to help you avoid those pitfalls. We have summarized some of these questions to help in your equipment decision-making process:

What costs am I looking at? You can **fully** equip your shop for under \$16,000, which includes the test system **and** support equipment. That's about \$550.00 per month on a lease purchase plan.

Can a system test both High and Low pressure cylinders? Yes. By working with you and understanding your objectives, we can design your system to handle a full range of cylinder requirements.

What kind of support can I expect from Galiso? Our field service technicians are available for on-site start-up installation and training. We are known to offer excellent assistance over our phone lines.

What is considered state-of-the-art testing? Some years back Galiso pioneered a much more accurate electronic expansion measuring system (EEMS) that eliminates guesswork. Our more advanced systems are computer controlled to calculate expansions, and can print **each** test result onto the Test Log.

How do I go about getting certified and in compliance? The best source is to contact **DOT** directly. We are glad to assist, but we are not authorized in any way to provide facility certification.

A local company is selling their old system. Should I start out that way? Often it costs little more to purchase new equipment, most used systems are 10-20 years old and do not have the advanced features that enhance productivity. Don't get lulled into the "price decision". There are other considerations you need to think about that can put you on course to owning a profitable business.

HELP US HELP YOU!

Please fill out the **Hydrostatic Test Systems Survey** and see our **System Selection Guide** in this catalogue. And, to further assist you in making the right step, Galiso offers a free **"Getting Started"** booklet (Use the Information Request Form below) that will show how to lay out the pit area, select the proper air system, point out electrical requirements, and consider the all important factor of ceiling height.

Have you contacted DOT? Do you know about third party inspectors? Are your people certified testers? Where do you get **HAZMAT training**? Is **leasing** correct for me? It's all contained in the information available from Galiso. As you progress in your planning, keep us in mind. Ask our Sales Department for ideas and suggestions that will help you step through start-up with minimal errors and confusion.

CYLINDER TESTING METHODS

Water Jacket Method:

The water jacket method for hydrostatic testing consists of loading a water filled cylinder into a sealed chamber (test jacket), which is also filled with water and is connected to a calibrated glass tube (burette) or Galiso's Electronic Expansion Measuring System. The Expansion Bowl (EEMS) was invented to replace the burette. The burette or Expansion Bowl is first zeroed, and the cylinder is then pressurised to its specified test pressure (test pressure requirements are contained in the U.S. Code of Federal Regulations, 49CFR173.34). This test pressure is held for a minimum of thirty seconds.

As pressure is applied to "inflate" the cylinder, the cylinder expands and forces water out of the test jacket and up into the Expansion Bowl or burette. After the thirty-second test time has elapsed, the Expansion Bowl or burette is then read to determine the Total Expansion (in cubic centimeters) of the cylinder under test pressure. The test pressure is released and the cylinder "deflates". As the cylinder shrinks to its approximate original size, water is allowed to drain back into the test jacket from the burette or Expansion Bowl. In most cases, the cylinder will not return to its original size, having been slightly stretched by the pressurization process.

This stretching is called the Permanent Expansion. The difference between the "Total Expansion" and the "Permanent Expansion" is called the Elastic Expansion. The Percent Expansion of the cylinder is determined by the following formula:

$$\text{Percent Expansion} = (\text{Permanent Expansion} / \text{Total Expansion}) \times 100$$

When the Percent Expansion exceeds the predetermined limits for the cylinder being tested, the cylinder must be condemned and removed from service. A high percent expansion value is an indication that the cylinder metal has lost its elasticity, or that there has been excessive thinning of the cylinder wall and that the cylinder is no longer safe for use.

All test records must be saved and maintained for the duration of the requalification. Plus (+) stamped cylinders may be filled to an additional 10 percent beyond the rating, which is stamped on the cylinder shoulder. Star (*) stamping makes the cylinder eligible for an extended ten-year re-test interval. The Water Jacket Method of testing compressed gas cylinders is the only hydrostatic test method that qualifies cylinders for filling to 10% over service pressure.

The procedures and requirements for plus stamping and star stamping are found in 49 CFR 173.302(c) for plus stamping, and 173.34(e)(16) for the star. REE values for common cylinders can be found in Compressed Gas Association Pamphlet C-5, "Cylinder Service Life, and Seamless High Pressure Cylinders". This pamphlet is available from Galiso, or from the Compressed Gas Association at the address indicated above.

DIRECT EXPANSION METHOD (DE):

During the direct expansion test, the cylinder is completely filled with water and the test connection is then screwed into the cylinder neck. Water is pumped into the cylinder until the desired test pressure is achieved. (Test pressure requirements are contained in the U.S.

Code of Federal Regulations, 49CFR173.34.

The volume of water that must be pumped into the cylinder to reach the test pressure is measured to determine the Total Expansion. The volume of water that is expelled from the cylinder when pressure is released is measured to determine the Permanent Expansion.

Because air has a different compressibility factor than water, air trapped inside the cylinder will cause inaccurate test results. So, it is very important that the cylinder is completely filled with water to eliminate trapped pockets of air. The weight of the water contained in the cylinder, the test pressure, test volume(s) and temperature are used to determine the compressibility factor for calculation of the expansion values.

DOT Regulations prevent the Direct Expansion Method from being used to qualify cylinders for filling to 10% over service pressure and therefore forbid the Direct Expansion test method to be used to re-qualify plus ("+") stamped cylinders. The Direct Expansion test method is discussed in detail and example calculations given in CGA pamphlet C-1, "Methods for Hydrostatic Testing of Compressed Gas Cylinders".

While not generally practiced in the U.S., the U.S. Code of Federal Regulations permit that certain specified cylinders only (and used exclusively in non-corrosive service) do not require the total and permanent expansion to be calculated. For such cylinders, the Proof Pressure method may be used.

PROOF PRESSURE METHOD (PPT):

The Proof Pressure Test involves pressurizing a cylinder to the appropriate test pressure and then thoroughly inspecting the cylinder, while under pressure, for indications of leaks, deformations or any indication of possible failure.

ULTRASONIC TESTING (UT) METHOD:

This method of cylinder testing was introduced in the U.S. on an exemption basis in 1994. UT differs from other test methods in that the cylinder valve and contents remain intact, as no water is used to pressurize the cylinder in this testing procedure.

The UT test involves positioning the cylinder on a rack of rollers, which rotate the cylinder. During the rotation cycle, the entire cylinder sidewall is examined by the inspection probe, which transmits Ultrasonic energy into the cylinder in the form of "ping-like" sonar soundings from multiple transducers. A longitudinal beam transducer sends a pulse that echoes straight off the back wall of the cylinder, measuring the time it takes the echo to return, thus measuring the thickness of the cylinder wall, and confirming adequate coupling to the cylinder. Shear wave, or angle beam transducers send sound waves diagonally through the cylinder wall, detecting any cracks, pits, or flaws. These 'soundings' are recorded electronically and reviewed to ensure that each cylinder is safe for continued use.

GALISO TEST SYSTEMS SELECTION GUIDE

	Console	Test Jackets	Nominal Test Rate	Test Log
Recortest III	Computer Controlled FULLY Automated Testing	2 ~ 4, & 12~36 inches	25 ~ 30 Cylinders per hour	Printed
Recortest/ Open	Computer Controlled FULLY Automated Testing	2 ~ 4, & 12~36 inches	10 ~ 15 Cylinders per hour	Printed
GTC 10K	Manually Controlled testing	Single; 12~ 36 inches. (Double as an option)	6 ~ 8 Cylinders	Manual*

NOTES:

Software: Both Recortest Test Consoles contain software to compute expansion calculations, notify the operator that the cylinder passed or failed, and prints out a complete and accurate test log of daily test results.

* The GTC Test Console is available with an optional HydroLog software package to use with a customer supplied PC and printer. Information taken from the console is keyed into the PC to perform expansion calculations, indicate test results, and provide a printed daily Test Log.

HYDROSTATIC EQUIPMENT SET-UP CHECKLIST

Please consult the [Systems Selection Guide](#) and complete the Hydrostatic Test Systems Survey to help us evaluate your needs.

To Keep On-Target Use This Handy Checklist:

- Place System Order
- Schedule Installation and Training
- Contact [DOT](#) for application
- Order 49 CFR Booklet, parts 100-185 and [CGA Pamphlets](#) as appropriate
- Complete function specific Hazmat Training
- Schedule IIA Inspector
- Test Pit Completed
- Air, Water, Electrical in place
- Set-up and Operator Training completed
- On-Site IIA System Inspection
- Submit Application to D.O.T.
- Receive Re-Tester Identification Number (RIN)
- Hold Open House Party!

SUGGESTED TEST PIT LAYOUTS

In preparation for installing a hydrostatic testing facility for compressed gas cylinders, Galiso suggests the following two basic pit configurations for optimum performance.

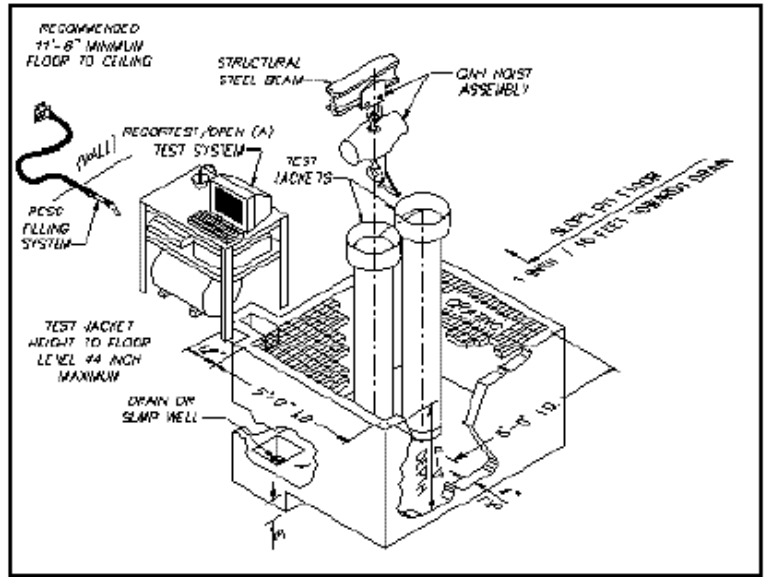

Illustration 1

The above lay-out is suggested for standard tall test jacket installation, with ample room to add a second test jacket at a later date without additional construction costs.

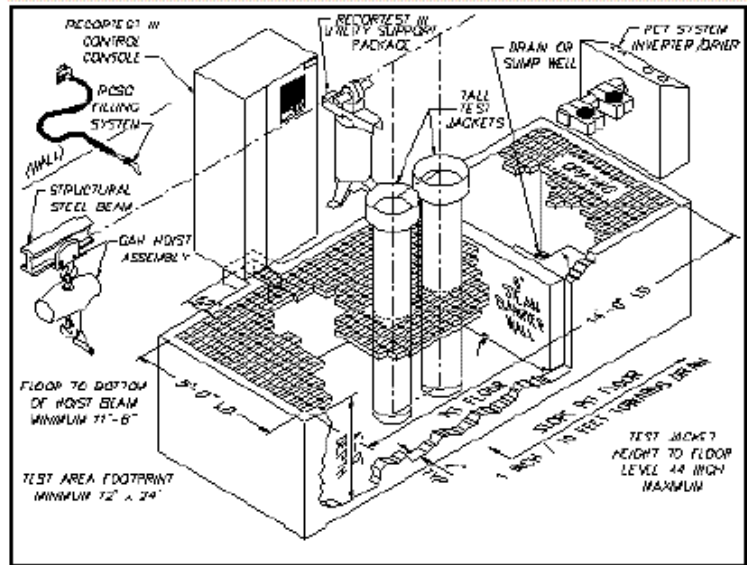

Illustration 2

The above extended pit is for standard tall test jacket(s) installation, but accommodates the PCT series Inverter / Drier dump area, complete with steam barrier.

GTC 10K MANUAL TEST SYSTEM

This economical, full-featured system has been designed for smaller volume production where ease of use, accuracy, and reliability are paramount to meeting the needs of your customers. GTC 10K is available in single or dual jacket configurations.

MANUAL TESTING:

In a matter of hours you will be able to master the operation and manually test on the GTC 10K console. The system requires minimal space yet has the capacity to manually test high or low-pressure cylinders such as dry powder and CO₂ fire extinguishers, SCBA, scuba, oxygen cylinders, propane, or refrigerant recovery tanks.

DESIGNED FOR LOW COST VERSATILITY AND ACCURACY

Each Component of the GTC Manual Console enables users to meet the requirements of the most demanding applications with versatility at a low cost. The GTC will test up to 8 Cylinders per hour manned by one skilled operator.

OPTIONS

Optional HydroLog software is available to record test information electronically. Simply enter data such as cylinder owner, serial number, and test readings taken from the LCD display into the customer supplied PC. The computer calculates the expansion percentages, indicates Pass/Fail, stores the results and prints out the Daily Test Log in a format that exceeds DOT requirements.

SYSTEM FEATURES

- Manual Test Process Control
- Electronic Expansion Measuring System with LCD Display
- Test Pressures up to 10,000psi *
- Tests up to 8 Cylinders per Hour
- Tests Steel, Aluminum, Composite and Exemption Cylinders
- High Pressure or Low Pressure Configuration *
- **Warranty:** 12 months when installed by Galiso.

NOTE: * Additional gauges may be required for Low Pressure testing.

PROOF PRESSURE TEST SYSTEM

This model option is specially designed, utilizing the GTC-10K console to supply test pressure to a series of special test adapters to perform proof pressure tests. Please contact our Sales Department for detailed information on this model.

SET-UP AND TRAINING

After construction of the test pit, the GTC 10K Manual Test System can be set-up in less than one day with the assistance of a Galiso Service Tech, followed by one day of operator training. The Operation Manual guides the operator through each step of the test procedure with clear, easy to understand instructions, enabling the average person to become proficient at testing, in about two hours.

STANDARD OPTIONS

- A two jacket option is available to make your system more flexible for accurate testing of various size cylinders.
- The GTC-10K Test System offers a selection of EEMS (Electronic Expansion Measuring System) to allow for measurement of larger volume expansions on large cylinders (i.e. One Ton Containers).

SPECIFICATIONS:

Dimensions: 18"L x 24"W x 65"H

Electrical Requirements: 110/120 Volt, 50/60Hz, 8 W

Air Requirements: 100PSI @ 10 CFM

Water Requirements: 6 GPM/ 30 LPM @ 60 PSI

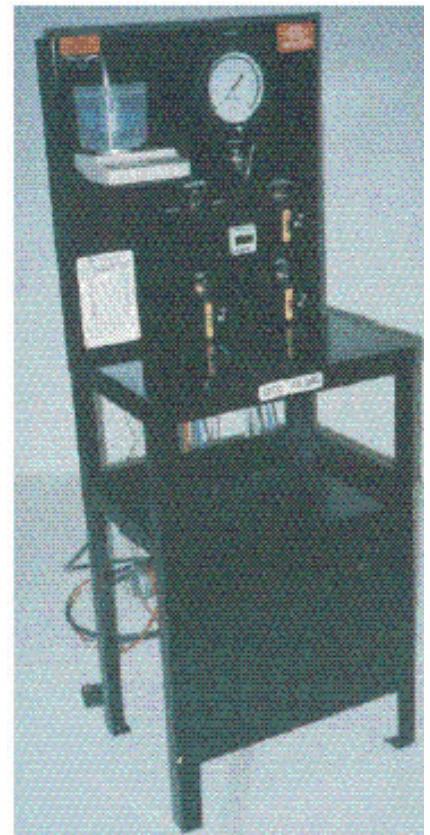

GHH AND OHH TEST HEADS

INTRODUCTION

The **GHH**, (Clean), and **OHH**, (Dirty) **Hydraclose Test Heads** are designed to dramatically reduce the set-up time for testing by pneumatically sealing the head to the test jacket, while also sealing the cylinder test connection.

FEATURES

Beginning with a slight turn of the test head, the head locks safely into place. As the low-pressure airline is attached to the head, the rubber boot portion of the test head expands to create a leak-proof closure. This simultaneously activates a diaphragm to compress the speed seals in the cylinder neck ensuring a fast leak-proof connection every time.

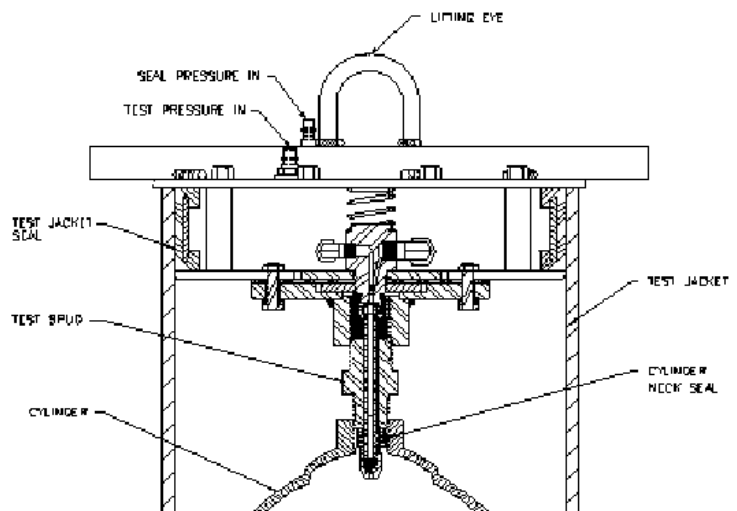

There are **two basic models** of the Hydraclose Test Head:

1. The **GHH** (Clean) Hydraclose Test Head is designed for general cylinder testing of "clean" cylinders such as oxygen, specialty gases, or argon where the presence of oil contamination is absent.
2. The **OHH** (Dirty) Hydraclose Test Head is designed for systems that will be testing both "clean" and "dirty" cylinders. The use of this head will reduce the possibility of cross contamination between clean and dirty cylinders.

Test heads can be ordered in the standard "H" (threaded) configuration or the innovative "G" style configuration. This "G" style uses a quick-connect spud that simply snaps either a 1/2inch, 3/4inch, or 1 inch spud in place without having to place the head in a vice, wrap threads with Teflon tape and wrench in to seal. This widely acclaimed feature has saved countless hours in shops of all sizes.

Hydraclose Test Heads are available in 12", 14", 18", and 24" nominal diameters, each designed for up to 10,000psi test pressure.

Galiso also provides 30" & 36" Closure test heads on special order for large cylinder testing applications.

OPTIONS:

- Hydraclose Test Heads are available in Stainless Steel by special order.
- Test Head Extended connections are available in "G" and "H" style for cylinders with guarded necks.

SPECIFICATIONS:

Air Requirements: 90PSI (Head Seal Pressure)

Maximum Test Pressure: 10,000 PSI

GTJ HYDRACLOSE TEST JACKET

Introduction

The GTJ, Galiso Hydraclose Test Jacket is an integral component of all Galiso test systems. The GTJ water jacket is specially designed to accommodate the Hydraclose Test Head and its associated plumbing

Features:

- The Hydraclose Test Jacket contains one or more burst disk crystals, (depending on the diameter of the jacket), a drain valve, a splash shield and connection hoses that attach to the Hydraclose Test Head.
- Test Jackets are available in overall heights of 48 ½ (Short) for testing scuba, SCBA, or other cylinders less than 33" in height, and 84 ½ overall height for testing cylinders up to 68 ½ (Tall) in height. Test Jackets may be custom ordered in specified lengths to fit your application needs.
- The Hydraclose Test Jacket is available in 12", 14", 18", and 24" nominal diameters. Galiso also provides 30" & 36" Test Jackets on special order for large cylinder testing applications.
- The Hydraclose Test Jacket provides a safety-locking device to contain the cylinder in case of rupture.

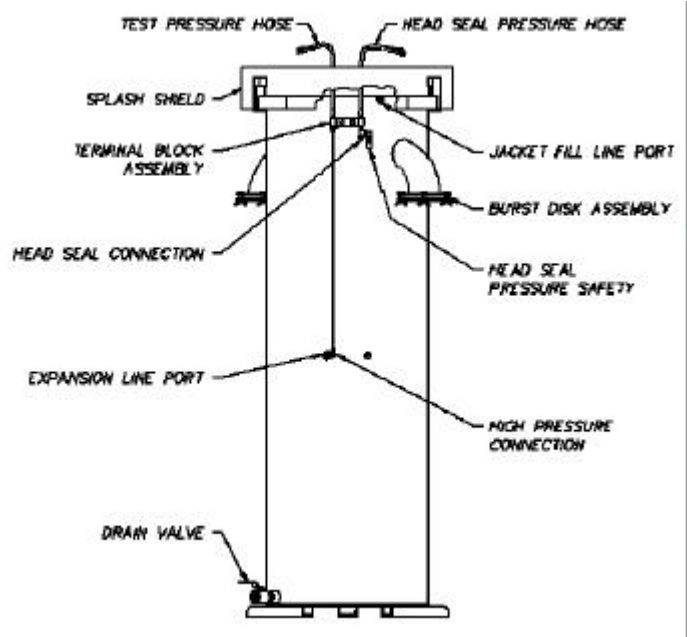

Options:

- The Hydraclose Test Jacket is available in Stainless Steel by special order.
- The Hydraclose Test Jacket is available with an OTJ (dirty) plumbing option to accommodate testing dirty cylinders using the OHH (dirty) Test Head.

SPECIFICATIONS:

Max Test Pressure: 11,000psi

Warranty Terms

- DURATION:** Galiso provides a one-year warranty from date of purchase, to the original purchaser, for standard products, unless otherwise specified. For all spare parts purchases, Galiso provides a 90-day warranty unless otherwise specified. Soft goods such as our speed seals, and O-rings, which are subject to wear in the normal course of operation, are not covered under this warranty.
- COVERAGE:** Galiso manufactured equipment is warranted against defective materials or workmanship. THIS WARRANTY IS VOID IF:
 - THE EQUIPMENT HAS BEEN DAMAGED BY ACCIDENT OR UNREASONABLE USE, IMPROPER SERVICE/MAINTENANCE, IMPROPER INSTALLATION, ABNORMAL OPERATING CONDITIONS, NEGLIGENCE, REPAIR BY ANY PERSON NOT AUTHORIZED BY GALISO, INC. OR OTHER CAUSES NOT RELATED TO MATERIAL DEFECTS OR WORKMANSHIP.
 - THE SERIAL NUMBER HAS BEEN ALTERED OR DEFACED.
- PERFORMANCE:** Galiso reserves the right to make warranty determination only after inspecting the item at the Galiso manufacturing facility. If the warranty determination indicates that the defective item is covered under warranty, the item will be repaired or replaced with same parts/items or parts/items of equivalent quality, at the option of Galiso. In the event of replacements, the replacement unit will continue under the original equipment warranty or carry a 90-day warranty, whichever is longer. No charge will be made for warranty repairs, and/or replacements. All freight charges are the responsibility of the customer requesting warranty service.

If the warranty determination indicates that the item is not covered by warranty, a repair/replacement cost estimate will be submitted to the purchaser for approval prior to initiating any repair work.
- CLAIMS:** In the case of equipment malfunction, notify Galiso (+44 1444 248884) and provide the Model Name, Model Number, Serial Number and a description of the problem. Return Authorization Number, shipping and/or service information will be provided on receipt of the required information.
- SERVICE EQUIPMENT:** Galiso attempts to make available, whenever possible, a limited amount of service equipment at a minimal use charge, plus freight expense, for those customers wishing to avoid downtime during repair of their equipment. Such items are available on a first come, first served basis and are billable at the specific service charge applying with a one-month minimum.
- MODEL CHANGES:** Galiso reserves the right to make changes in materials and specifications, without notice. Galiso may offer, for a stipulated fee, the opportunity to upgrade your equipment to the latest configuration.
- DISCLAIMERS:** Galiso provides technical data and assistance to aid customers in the selection and use of our products. There are no implied warranties of merchantability nor suitability for a particular purpose associated with the transmittal of technical data and/or customer assistance.

Galiso does not assume liability for any consequential, incidental, or special damages. Liability under this warranty is limited to repairing, or replacing Galiso equipment items returned to the factory or an authorized facility.

HYDROSTATIC INFORMATION REQUEST FORM

Dear Customer,

Thank you for inquiring about our test systems. We ask you for the following information to properly quote a system specific to your needs. If you have any questions while answering, please call our office at +44 1444 248884 and ask for our Sales Department. Upon completion, please fax this document to us at +44 1444 242767 or email us at Galiso@bancroft.co.uk.

YOUR COMPANY: _____
 ADDRESS: _____
 CONTACT: _____
 PHONE: _____ FAX: _____

ARE YOU PRESENTLY USING A HYDROSTATIC TEST SYSTEM? PLEASE TELL US!

MANUFACTURER: _____ MODEL: _____ YEAR INSTALLED: _____
 TEST JACKET(S): DIAMETER: _____ LENGTH: _____
 YOUR PIT DIMENSIONS ARE: LENGTH: _____ WIDTH: _____ DEPTH: _____
 CURRENT MAX NUMBER OF CYLINDERS TESTED PER HOUR: _____ PER MONTH: _____
 PROJECTED MAX NUMBER OF CYLINDERS TESTED PER MONTH, 5 YEARS FROM NOW: _____

CHECK EACH OF THE FOLLOWING CYLINDERS THAT YOU WILL BE TESTING:

<input type="checkbox"/> OXYGEN	<input type="checkbox"/> MEDICAL "D & E"	<input type="checkbox"/> FIRE EXTINGUISHER:
<input type="checkbox"/> SCUBA	<input type="checkbox"/> ARGON	<input type="checkbox"/> CO2
<input type="checkbox"/> SCBA	<input type="checkbox"/> PROPANE	<input type="checkbox"/> HALON
<input type="checkbox"/> CO2	<input type="checkbox"/> FREON	<input type="checkbox"/> OTHER: (Please Specify Below)
<input type="checkbox"/> N2	<input type="checkbox"/> CHLORINE	<input type="checkbox"/>

CYLINDER DIAMETER: SMALLEST: _____ LARGEST: _____
 CYLINDER HEIGHT: SHORTEST: _____ TALLEST: _____
 TEST PRESSURES (PSI): LOWEST: _____ HIGHEST: _____
 CYL. EXPANSION (CC): MINIMUM: _____ MAXIMUM: _____
 CYLINDER THREADS ARE: TAPERED: _____ STRAIGHT: _____
 CYLINDER NECK INNER DIAMETER: 1/2": _____ 3/4": _____ 1": _____

DO YOU HAVE: 180°F WATER HEATER INSTALLED? ___ CAPACITY IN GALLONS: _____

COMPRESSOR? MAXIMUM PSI: _____ MAXIMUM CFM: _____ HORSEPOWER: _____

YOUR CURRENT ELECTRICAL SUPPLY? AMP: ___ VOLT: _____ PHASE: _____ CYCLE: _____

ARE THERE ANY RADIO OR TELEVISION TOWERS WITHIN 1/2 MILE RADIUS OF YOUR FACILITY?
 Yes/No

THE HEIGHT FROM THE BOTTOM OF THE CEILING STRUCTURE (STEEL BEAM)
 TO THE FLOOR? _____

THE TOTAL DIMENSIONS OF YOUR TESTING AREA: LENGTH: _____ WIDTH: _____

YOUR SIGNATURE: _____

DATE: _____

Upon completion, please fax to +44 1444 242767.

Or call us on +44 1444 248884 Thank you!